

**Engineering Submittal Form – MA-12SF4**

**CERTIFIED FOR:**

Job Name:	Customer Name:
Location:	Customer P.O.:

**Recommended Usage:**

Use as a free standing; non-penetrating support stand for Single or Multiple runs of piping, conduit, duct, refrigeration lines, solar panels, cable trays and equipment supports. Accepts industry standard accessories.

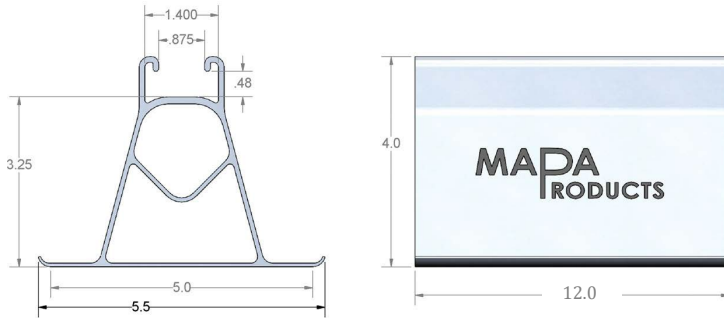

**Standard Composition:** Extruded Aluminum with integrated 1 5/8" shallow strut, Solid flat base with rolled edges. Available lengths pre-cut up to 10'. 100% recyclable material. Made in USA.

**MAPA Products Supports are designed and manufactured in accordance with MSS SP-58-2002 and MSS SP-69-2002.**

Refer to MAPA Products "Recommended Installation Guidelines" for standard installation and spacing recommendations.

**Composition:**

- Extruded Aluminum w/ Integrated 1 5/8" shallow strut
- Strut Length 12"
- Base Dimensions 5" X 12"
- Footprint 60 sq in.
- Load Factor 5 PSI

**Optional Accessories:**

- Add Suffix "P" Standard pad.
- MWP1016- 9.2mm thick rubber walk pad
- Snap-N-Strut Clamps (Refer to SNS selection chart for sizing)

**Certification Data**

Support Pad Options							
QTY	NP	P	WP	SNS Selection	Pipe Size	Service	Notes & Options
	<input type="checkbox"/>	<input type="checkbox"/>	<input type="checkbox"/>				
	<input type="checkbox"/>	<input type="checkbox"/>	<input type="checkbox"/>				
	<input type="checkbox"/>	<input type="checkbox"/>	<input type="checkbox"/>				
	<input type="checkbox"/>	<input type="checkbox"/>	<input type="checkbox"/>				
	<input type="checkbox"/>	<input type="checkbox"/>	<input type="checkbox"/>				

<b>DRAWN</b>				<b>CHECKED</b>		<b>DATE</b>	<b>DWG.NO.</b>
							<b>Doc. #: M-13809</b>