

# MA-6SF4

**MAPA**  
PRODUCTS®

Versatile Practical Affordable

## A-Series Strut Support

### Model: MA-6SF4



### Features

- Made in the USA
- 100% recyclable material
- Extruded aluminum design
- Pre-cut 6" up to 10'
- Solid flat base with rolled edges
- Integrated 1 5/8" Strut
- Industry standard accessories
- Single/multiple piping runs
- Equipment supports
- Load factor of 5 PSI
- Available with adhered isolation pad
- Simple time saving installation
- Patent Pending

### Overview

with integrated 1 5/8" shallow strut available in lengths from 6 inches up to 120 inches.

Used within the recommended load limits, the A-Series is designed as a free standing/non-penetrating pipe support stand for applications including natural gas, conduit, refrigeration; ductwork, cable trays, solar panel and equipment support.

A-Series supports provide a price conscious alternative that is simple to install, saving time and labor on the project.

Integrated strut allows the use of any industry standard strut accessory to provide additional versatility.

Simple installation, evenly space the supports within their load rating; for piping provide an additional support within two feet of each change in direction.

### Contact Information



### Engineering Specification Guide

**A-Strut Series Pipe Supports:** Available in lengths of 6, 8, 10 and 12 inches. Change strut length in model number as shown below.

#### Engineering Specification & Detail:

Support for pipe, conduit, duct, refrigeration lines, solar panels, cable trays and equipment support shall be MAPA Products A-Series Supports. Manufactured from extruded aluminum with an integrated industry standard strut designed to allow for a "free-standing", "non-penetration" installation that can incorporate readily available strut accessories.

Designed and manufactured in compliance with the MSS SP-58 and MSS

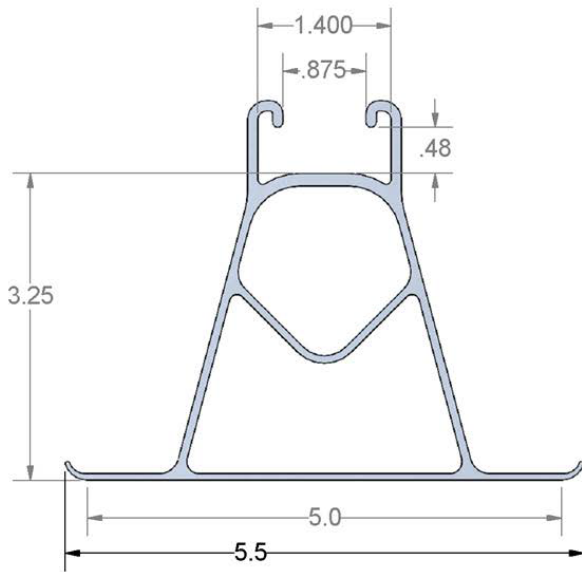

## Advantages

- Made in the USA
- Simple labor-saving installation, ready to use out of the box with no assembly needed.
- Extruded Aluminum with integrated 1 5/8" shallow strut allows the use of any standard strut accessory.
- Versatile design allows for a variety of Mechanical, Electrical and Plumbing applications.
- Support for pipe, conduit, duct, refrigeration lines, solar panels, cable trays and equipment support.
- May be used with any flat surface including BUR, membrane, metal and foam roofs.
- Order or cut to desired length allowing virtually unlimited options and customized solutions.
- Lightweight and easy to transport.
- Intergraded pad or Heavy Duty Walk Pad.
- Supports green building requirements; aluminum bases are made from recycled material and can contribute to earning LEED credit
- Limited Lifetime Warranty, see MAPA Products warranty documentation for complete details.

## Contact Information



MAPA Products, LLC.  
103 CJ Wise Pkwy, Service Road West  
Naples, TX 75568

**HOURS:** M-F 8:00am - 4:30pm (CST)  
**Phone:** 903-781-6996  
**Fax:** 903-781-6997  
**Email:** [sales@mapaproducts.com](mailto:sales@mapaproducts.com)

